

TITÄ

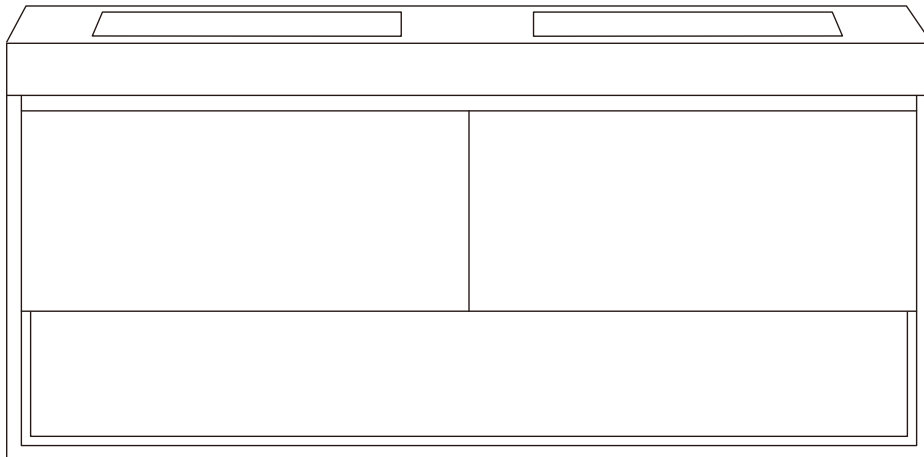

SINK BASE
AIGA6019

VANITY CABINET + VANITY TOP

VANITY SET:AIGA6019

INSTALLATION INSTRUCTIONS



PRODUCT PACKAGE COMPONENTS/TOOLS REQUIRED

VANITY COMBINATION
MAIN COMPONENTS

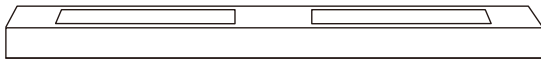

Basin Vanity **x 1**

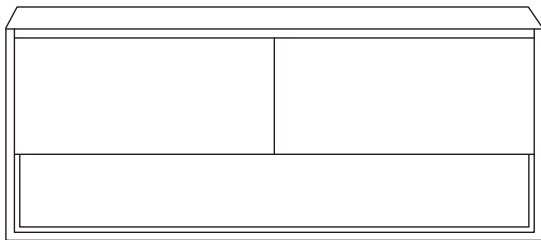

Vanity Base Cabinet **x 1**

INSTALLATION ACCESSORIES

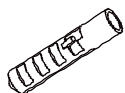

x 3

Wall Anchors



x 3

Screws 1 1/4"

P-TRAP AND POP AND POP-UP
INSTALLATION DIAGRAM

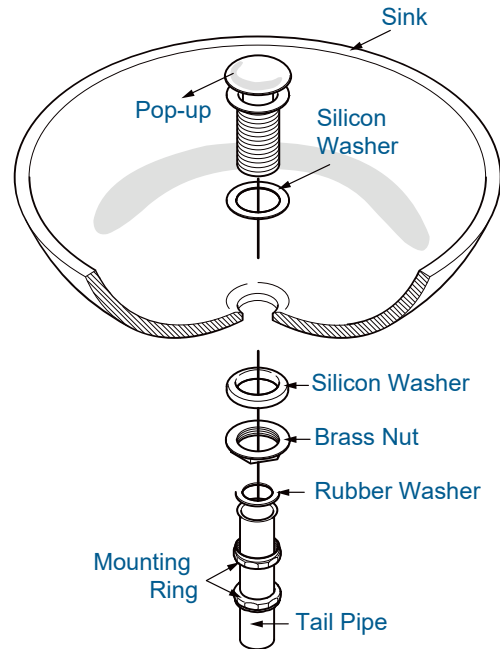

TOOLS REQUIRED FOR INSTALLATION
(NOT INCLUDED)



Safety Glass

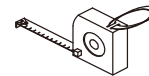

Tape Measure

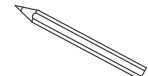

Pencil/Marker



Silicone

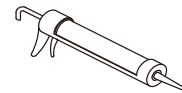

Caulk Gun

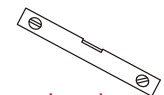

Level



Soft Cloth
or Blanket



Pliers



Electric Drill
with DrillBits

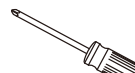

Philips
Screwdriver



Stud Finder



Hammer

Other tools may be required



DIMENSIONS & SPECIFICATIONS

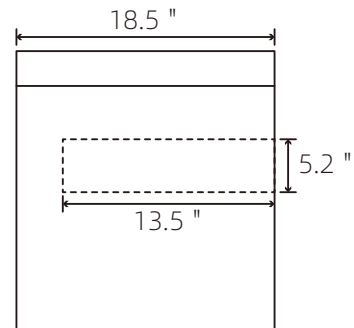
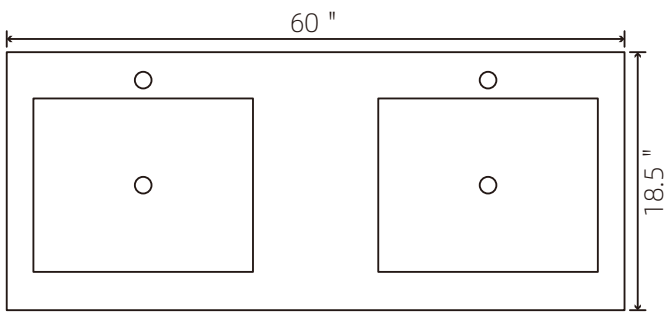

Side View

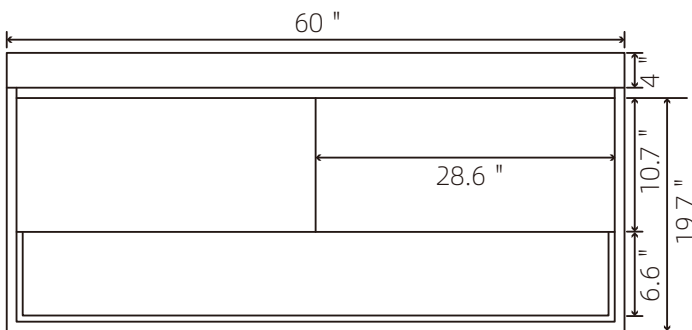

Front View

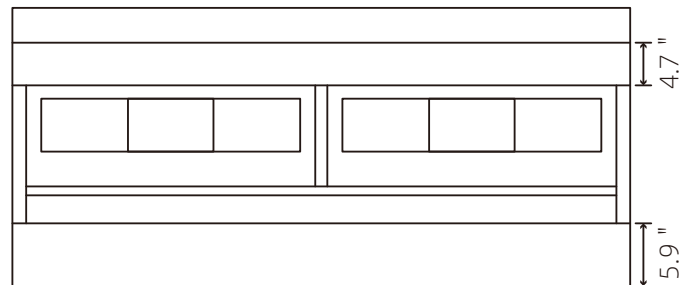

Back View

ATTENTION! Due to manufacturing process any dimensions may have a tolerance up to 3/8". All sizes are for reference only. It is highly recommended to pull all dimensions of actual model for installation and measuring purposes.

ATTENTION! If two or more vanity cabinets are installed next to each other there will be a visible seam between vanity tops and between vanity cabinets or between drawer base cabinets.

VANITY INSTALLATION

Using a tape measure find a length of the vanity top and divide it by 2. The result of the division will be a center of the top. Using a tape measure find the center of the top and mark a dot on the wall just right above the top using a pencil. Using a level tool find a location of a second dot to draw a vertical line that will serve as installation center for the Vanity.

Measure the distance between installation brackets of the Vanity and divide it by 2. The result of the division will be a distance between the drawn center line and center of a drilled holes. Mark a center of the first hole and using a level find and mark a location for a second hole. Using an electric drill make the holes.

See Figure 1

Apply a silicone inside each hole. Insert wall anchors (a hammer may be needed if the holes are too tight.) Two people lift the vanity and let the two holes align (wall anchors and the brackets hole on vanity) Using a Philips Screwdriver insert the mounting screws into the wall anchors. Make sure that the vanity is secured safely on the wall.

See Figure 2

IMPORTANT! Using a stud finder locate wooden studs. Screws for mounting vanity must be installed in the wooden studs to support weight of the vanity.

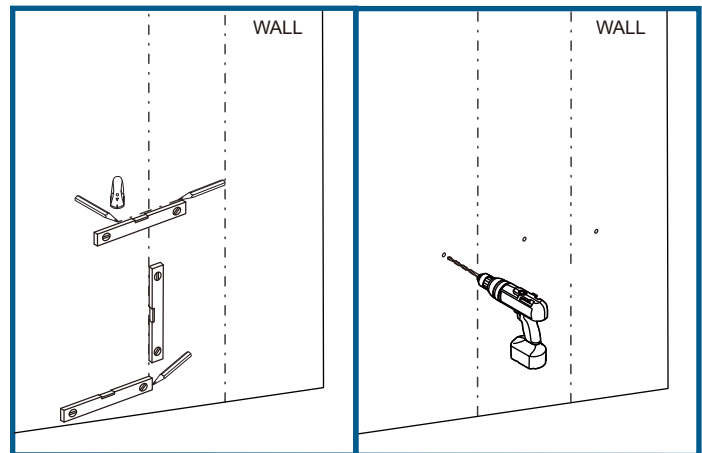

Figure 1

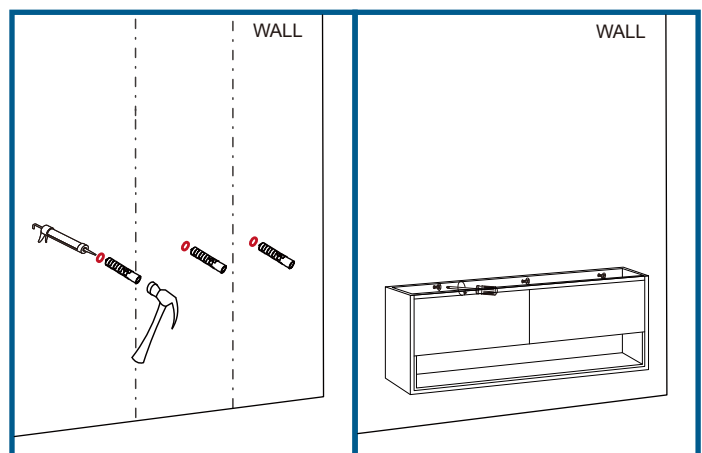

Figure 2

INSTALLATION STEPS

VANITY CABINET ASSEMBLY

Prior to installation of the glass vanity top you must apply a silicone layer by a perimeter of the vanity base cabinet and carefully lay down the vanity top on top of the vanity cabinet.

See Figure 1

Note (single vanity sink cabinet installation): Vanity top is slightly wider than the actual cabinet. Make sure that outstanding edges are equal at left and right sides.

Apply a silicone layer on the back side of the vanity top that will be adjacent to the wall.

Allow the silicone dry for 48 hours prior to the first use of the vanity cabinet.

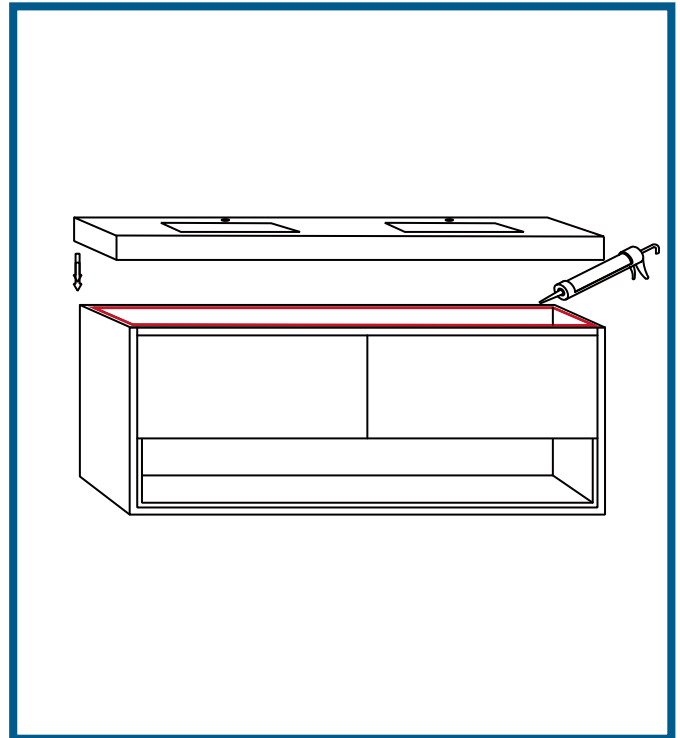

See Figure 1

INSTALLATION OF DRAWER BASE WITH SINK BASE CABINET

If drawer base is to be installed next to sink base you must apply a silicone layer to the countertop side adjacent to the sink base cabinet and the wall

Note: Allow the silicone dry for 48 hours prior to the first use of the vanity cabinet.

See Figure 2

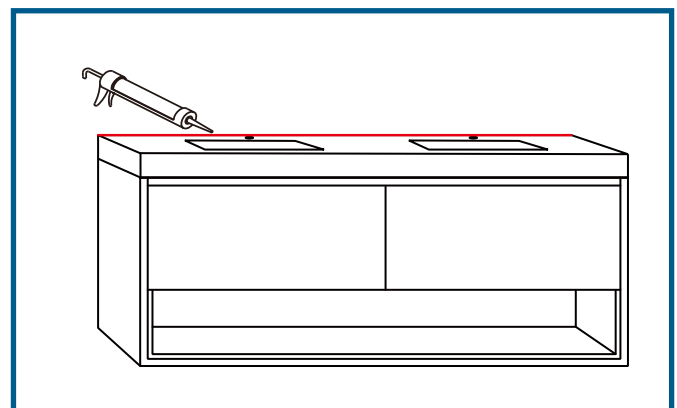

See Figure 2