

# Towel Rail Installation

- Read the instruction sheet carefully before installation.
- Installation should be completed by a professional electrician.
- Please dispose the package properly.

## tools required

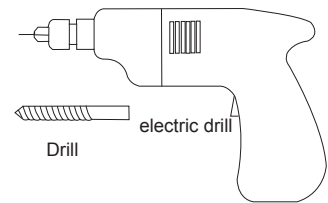
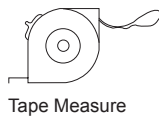
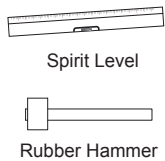
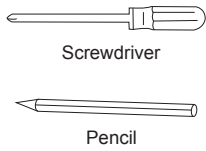

Blanking Plug

Airvent

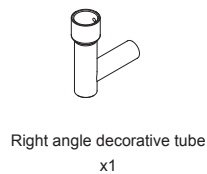
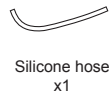
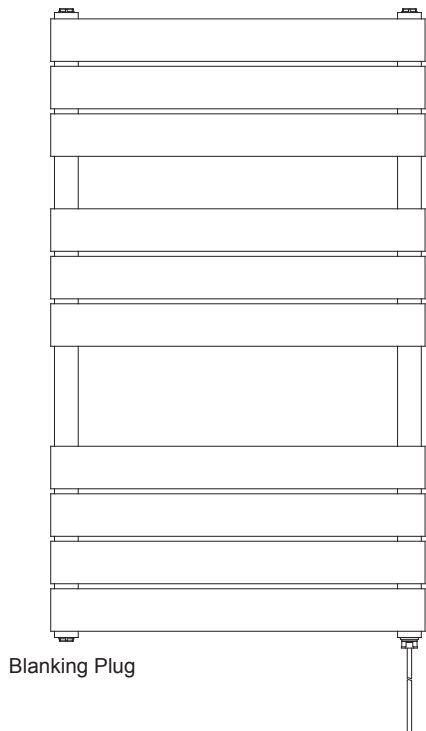

	Washer	x4
	Masonry Wall Plug (St4.8*60)	x4
	Expansion Pipe (Φ8*60)	x4
	Wall Bracket Core (Φ20*25)	x4
	Wall Bracket (Φ28*34)	x4
	Screw (M5*12 )	x4
	Cross Recessed Countersunk Head Screw (M6*25 )	x4
	Internal Hexagonal Wrench (S2.5x60)	x1
	Tapping Screw (St4*30)	x2
	Expansion Pipe (Φ8*36.5)	x2
	Cone Point Set Screw M5	x1
	Flat End Screw M5	x1

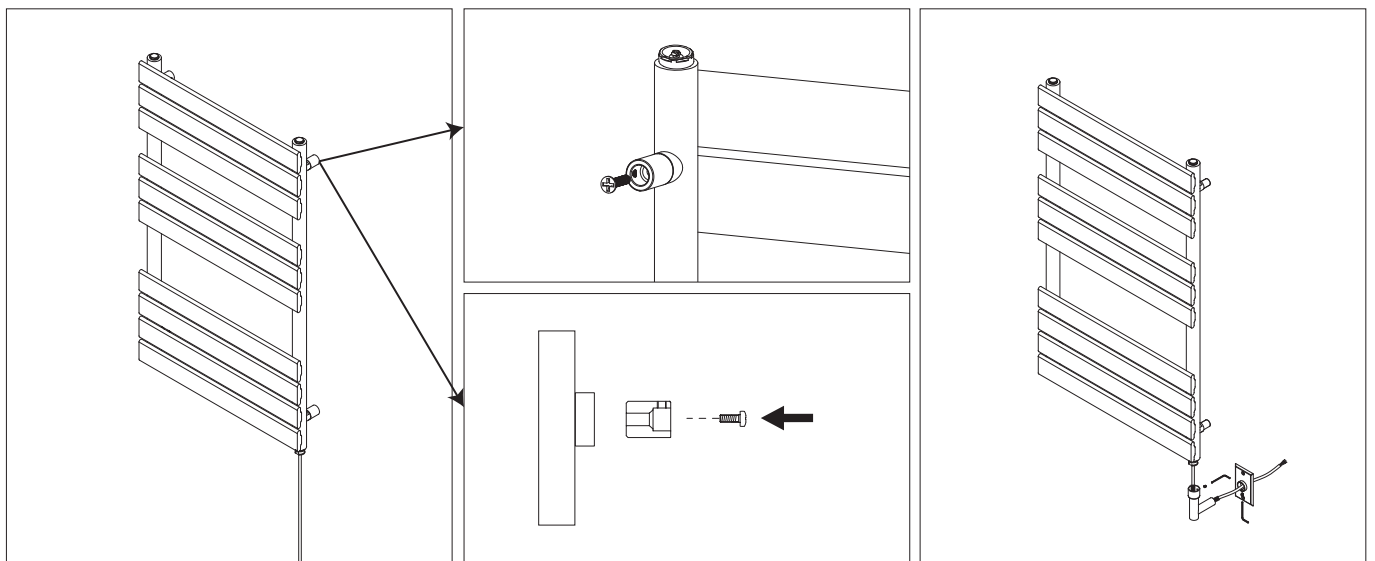

Step1. Fix the wall bracket cores to the back of the towel rail.

Step2. Get the power line through the silicone hose and then through the right angle decorative tube. Use internal hexagonal wrench and the screws to fix the decorative tube to the element. Get power line through the line pipe installed beforehand. This step is to confirm the position only.

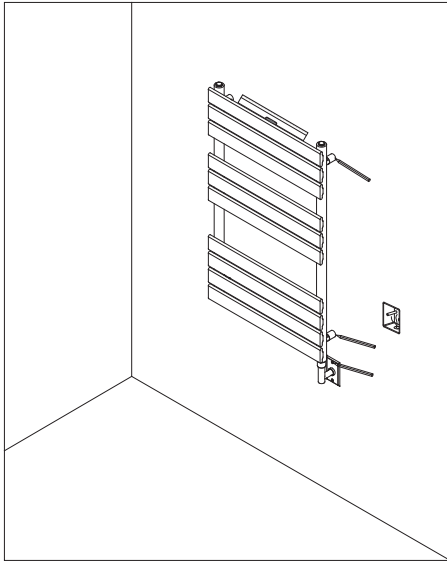

Step3. Position the towel warmer and the decorative cover plate in desired location. Check for level with the spirit level. Mark the positions of 4 wall brackets and decorative cover plate with a pencil.

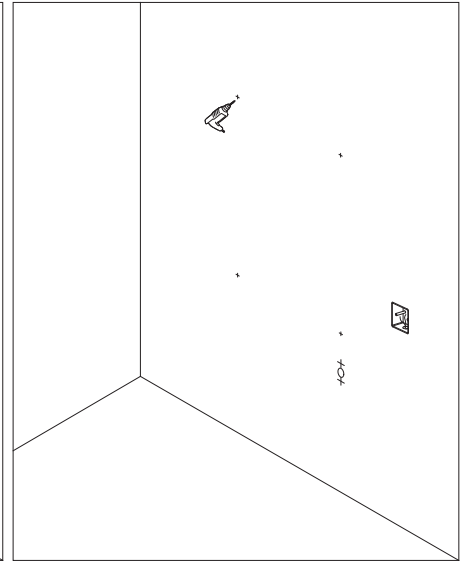
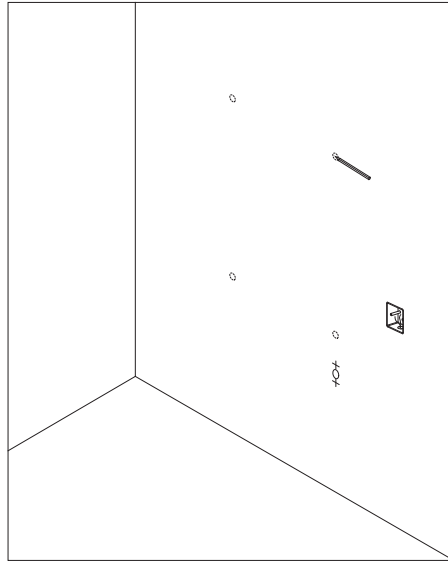

Step4. Drill holes in wall.

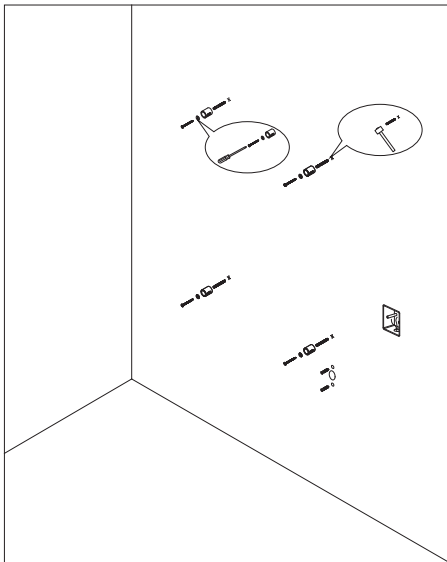

Step5. Hammer the wall anchor into the hole and fix the wall brackets to the wall with screws.

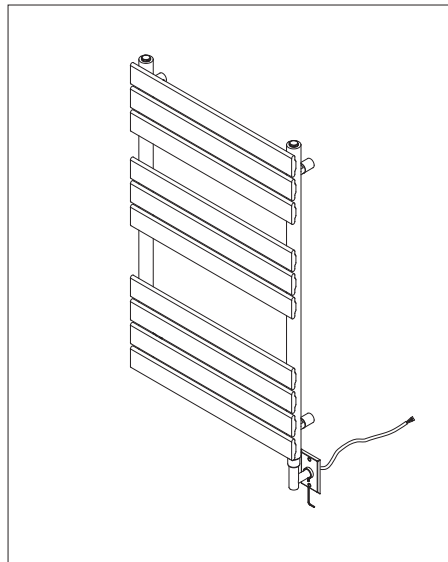

Step6. Loosen the set screw between the round decorative tube and decorative cover plate.

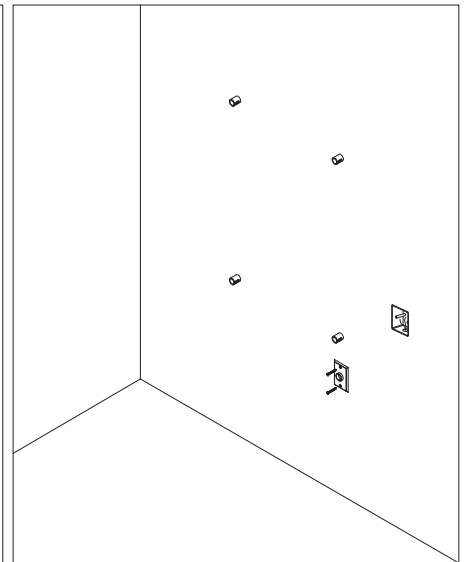

Step7. Fix the decorative cover plate onto the wall with tapping screws.

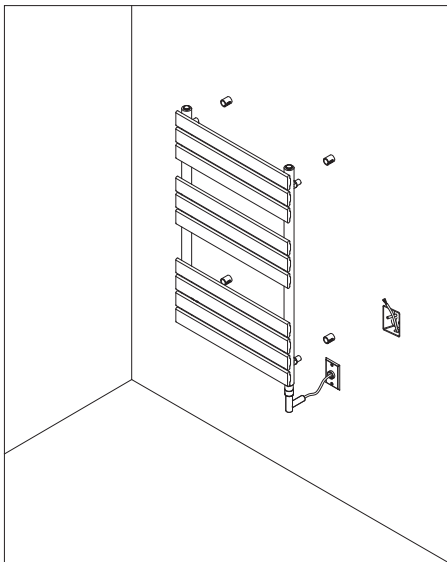

Step8. Slide electric wires through the decorative cover plate into the wall. Install towel warmer on the wall and secure the wall brackets with screws. Secure the round decorative tube and cover plate with set screw.

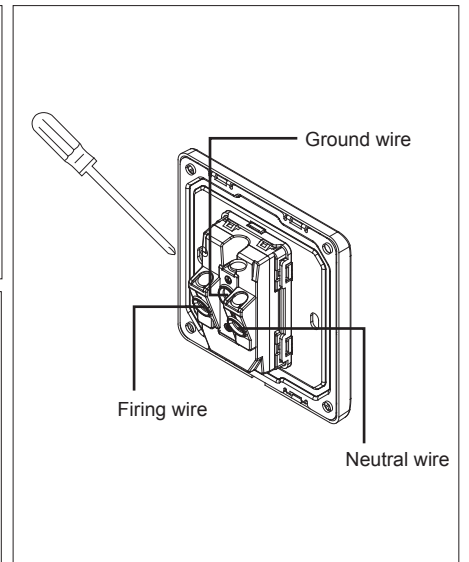
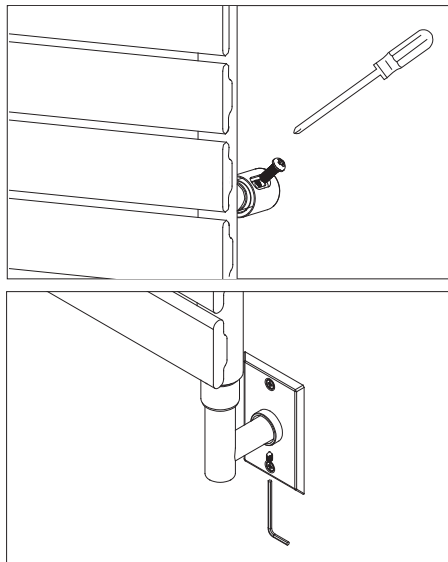

Step9. Connect the wiring with junction box.